






































## The (Art and) Science of Diagramming: Communicating Effectively Using Diagrams



**Ajilon**  University of Twente

## The Art and Science of Diagramming

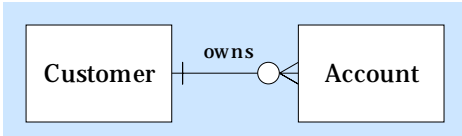
1. What is a (good) diagram?
2. The state of the art
3. How diagrams communicate
4. Principles for effective diagrams
5. Conclusion

	DATA	PROCESS	NETWORK	PROFILE	TIME	METHOD	STATE
Diagram							
Clear							
Complex							
Simple							
Useful							

▶ 1/5: What is a (good) diagram? 3

## What is a diagram?

A sentence in a graphical language



▶ 1/5: What is a (good) diagram? 4

## What is a “good” diagram?

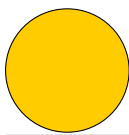
- 1
- A diagram is a sentence in a graphical language
- 2
- The purpose of any language is to communicate
- 3
- A “good” diagram is one that communicates effectively

**Cognitive Effectiveness = speed, ease and accuracy with which information content can be understood**


▶ 1/5: What is a (good) diagram? 5


## Why representation of diagrams is important

**Form**



**Content**





**Cognitive effectiveness**

▶ 1/5: What is a (good) diagram? 6

## The Art and Science of Diagramming

1. What is a (good) diagram?
2. The state of the art
3. How diagrams communicate
4. Principles for effective diagrams
5. Conclusion

Practitioners receive little or no training in how to produce good diagrams



▶ 2/5: The state of the art

8

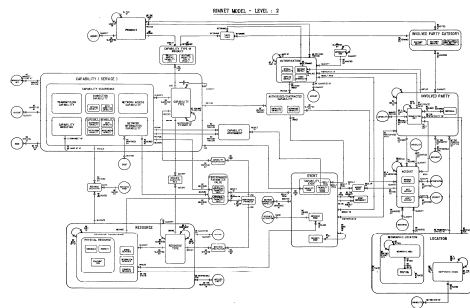
## Art or Science?



▶ 2/5: The state of the art

9

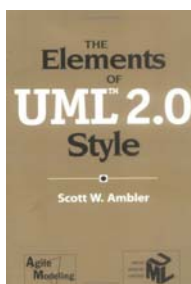
## A Real World Example



▶ 2/5: The state of the art

10

## Style Guides and Diagramming Standards



▶ 2/5: The state of the art

11


## Current diagramming practices



▶ Conclusion

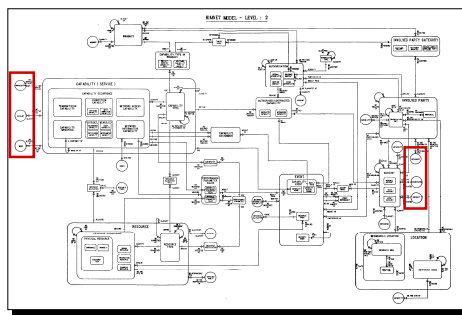
12

### First Commandment of Diagramming Practice: Thou shalt avoid line crossings



▶ 2/5: The state of the art 13

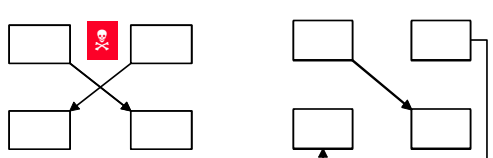
### A Real World Example



▶ 2/5: The state of the art 14

### Understanding of relationships

Path directness = path length + number of direction changes



Source: Ware, C., Purchase, H., Colpoys, L., & McGill, M. (2002): Cognitive Measurements of Graph Aesthetics. *Information Visualization*, 1(2), 103-110.

### The Elements of UML Style

6 THE ELEMENTS OF UML 2.0 STYLE

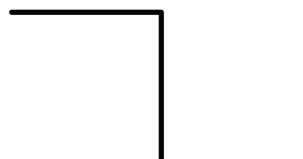
## 2. General Diagramming Guidelines

#### 2.1 Readability Guidelines

1. *Avoid Crossing Lines*  
When two lines cross on a diagram, such as two associations on a UML class diagram, the potential for misreading a diagram exists.

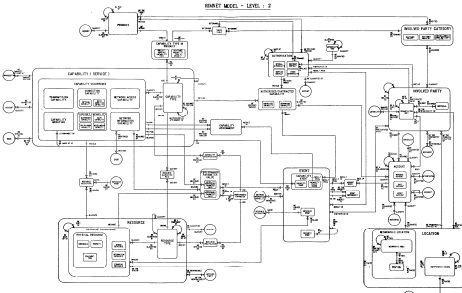
▶ 2/5: The state of the art 16

### 2nd Commandment of Diagramming Practice: Thou shalt use zigzag lines



▶ 2/5: The state of the art 17

### A Real World Example



▶ 2/5: The state of the art 18

### The Zigzag Line Guideline

Gestalt Law of Good Continuation

Source: Wertheimer, M. (1938). *Laws of Organization in Perceptual Forms*. In W. Ellis (Ed.), *A Source Book of Gestalt Psychology* (pp. 71-88). London: Routledge and Kegan Paul.

### Path directness

▶ 2/5: The state of the art

### The Zigzag Line Guideline

▶ 2/5: The state of the art

### The Elements of UML Style

THE ELEMENTS OF UML 2.0 STYLE

**3. Avoid Diagonal or Curved Lines**

Straight lines, drawn either vertically or horizontally, are easier for your eyes to follow than diagonal or curved lines. A good approach is to place symbols on diagrams as if they are centered on the grid point of a graph, a built-in feature of many computer-aided system-engineering (CASE) tools. This makes it easier to connect your symbols by only using horizontal and vertical lines. Note how three lines are improved in Figure 2 when this approach is taken. Also note how the line between A and C has been depicted in "step fashion" as a line with vertical and horizontal segments.

▶ 2/5: The state of the art

### Current diagramming practice

▶ 2/5: The state of the art

### CASE Tools provide little (or negative) assistance

▶ 2/5: The state of the art

### There must be another way...



“Here is Winnie-the-Pooh coming downstairs, bump, bump, bump on the back of his head. It is, as far as he knows, the only way of coming downstairs, but sometimes he feels that there really is another way, if only he could stop bumping for a moment to think of it...”

### Evidence-based Diagramming Practice

#### Evidence-based medicine (EBM)

- ★ Decisions about patient care based on the best available research evidence

#### Evidence-based diagramming practice (EDP)

- ★ Decisions about representation of diagrams based on theory and empirical evidence

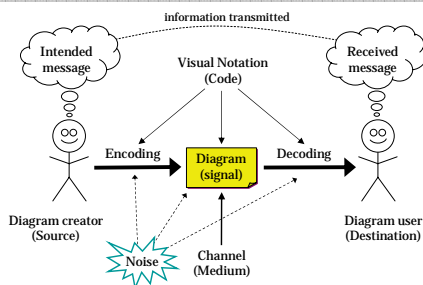
### The Art and Science of Diagramming

1. What is a (good) diagram?
2. The state of the art = Terrible
3. How diagrams communicate
4. Principles for effective diagrams
5. Conclusion

### The Art and Science of Diagramming

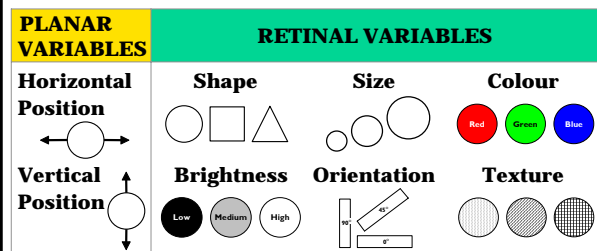
1. What is a (good) diagram?
2. The state of the art = Terrible
3. How diagrams communicate
4. Principles for effective diagrams
5. Conclusion

### Theory of Diagrammatic Communication

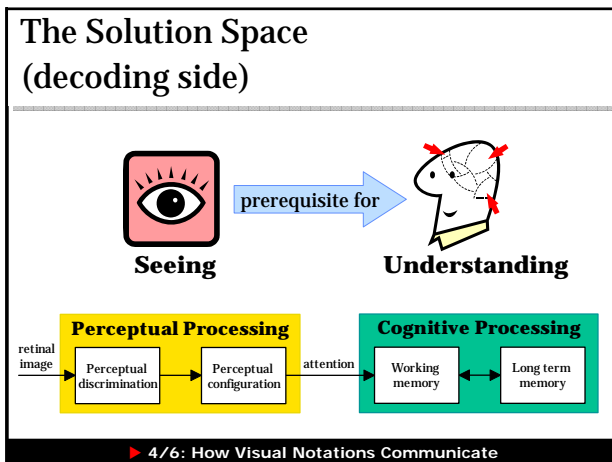
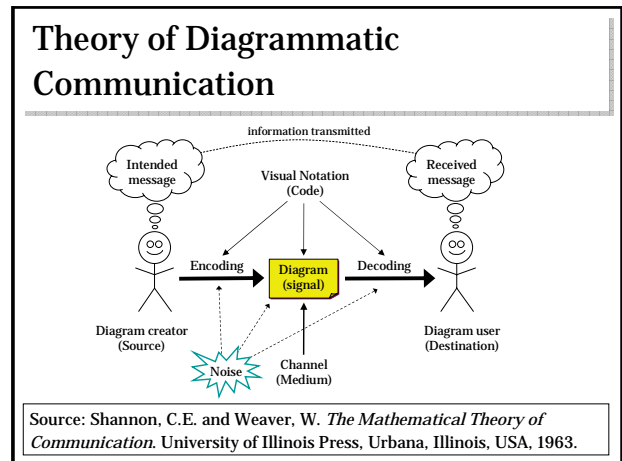
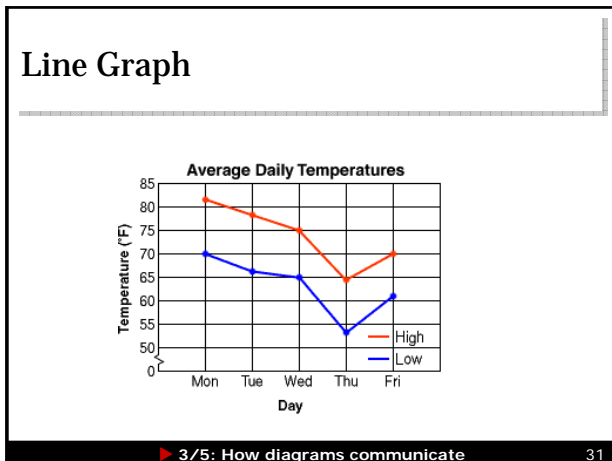


Source: Shannon, C.E. and Weaver, W. *The Mathematical Theory of Communication*. University of Illinois Press, Urbana, Illinois, USA, 1963.

### The Graphic Design Space (encoding side)

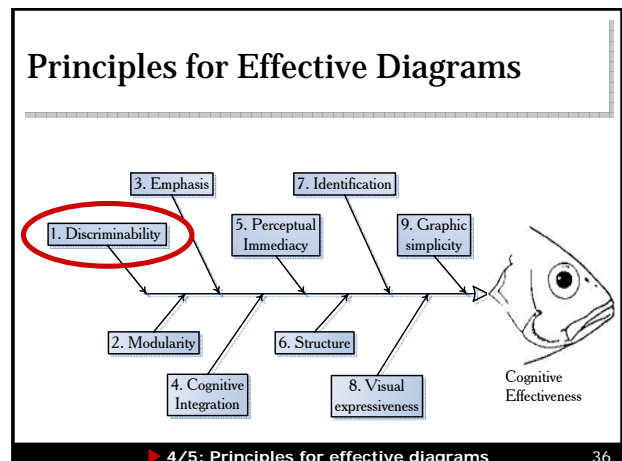


Source: Bertin, J. *Semiology of Graphics: Diagrams, Networks, Maps*. University of Wisconsin Press, Madison, Wisconsin, USA, 1983.



- ### The Art and Science of Diagramming
1. What is a (good) diagram?
  2. The state of the art
  3. How diagrams communicate
  4. Principles for effective diagrams
  5. Conclusion

- ### Principles for Producing Cognitively Effective Diagrams
- Based on evidence from a wide range of fields:
- ★ Cartography
  - ★ Cognitive psychology
  - ★ Diagrammatic reasoning
  - ★ Education
  - ★ Graphic design
  - ★ Graph drawing
  - ★ HCI (GUI design)
  - ★ Information visualisation
  - ★ Linguistics
  - ★ Psychophysics
  - ★ Semiotics
  - ★ Statistics
  - ★ Typography
  - ★ Visual perception
- 4/5: Principles for effective diagrams 35

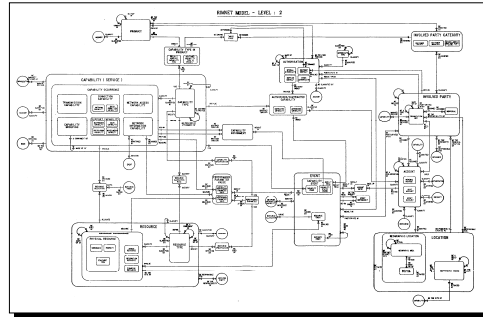


### Principle 1. Discriminability

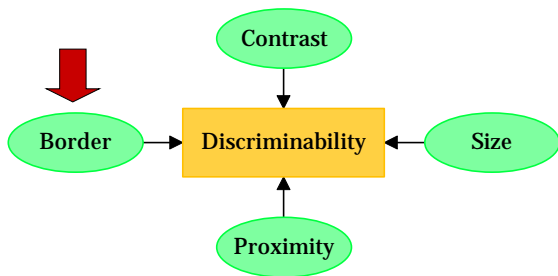


Diagram elements should be easy to see and differentiate from one other

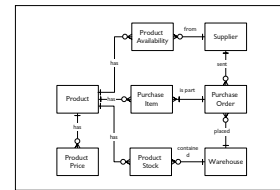
### A Real World Example



### Determinants of Discriminability



### Border



**Gestalt Law of Closure**

Source: Kulhavy, R.W., Lee, J.B. and Caterino, L.C. Conjoint Retention of Maps and Related Discourse. *Contemporary Educational Psychology*, 10, 28-37, 1985.

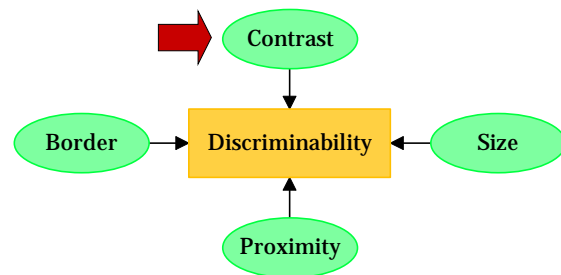
### The Elements of UML Style



#### 42. Avoid Diagram Frames

The *Batch Transcript Printing* diagram frame of Figure 9 adds a significant amount of visual clutter. The only real value that it adds is that it indicates the name of the diagram, information that could have been captured in a note if it needed to be depicted at all. Diagram frames are in effect generic boundary boxes for diagrams, and that purpose is accomplished just as well by the edge of your computer screen, whiteboard, or paper.

### Determinants of Discriminability

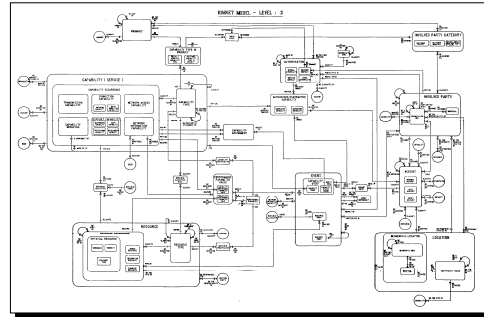


### Figure-Ground Ambiguity



▶ 4/5: Principles for effective diagrams 43

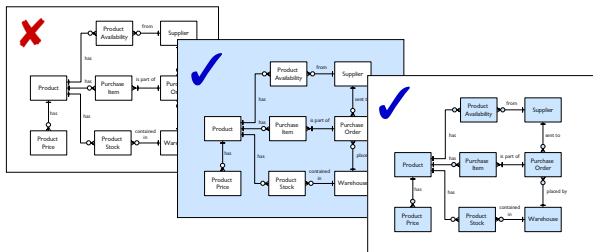
### A Real World Example



▶ 4/5: Principles for effective diagrams 44

### Contrast

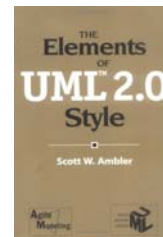
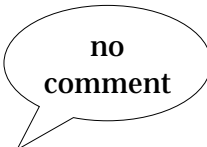
Gestalt Figure-Ground Principle



Source: Wertheimer, M. (1938). Laws of Organization in Perceptual Forms. In W. Ellis (Ed.), *A Source Book of Gestalt Psychology* (pp. 71-88). London: Routledge and Kegan Paul.

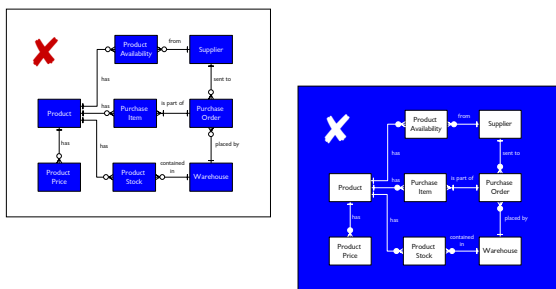
▶ 4/5: Principles for effective diagrams 47

### The Elements of UML Style



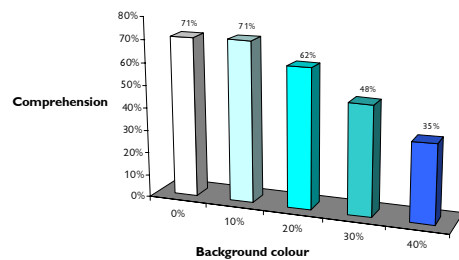
▶ 4/5: Principles for effective diagrams 46

### Contrast



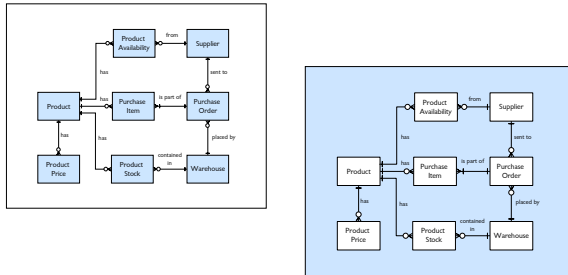
▶ 4/5: Principles for effective diagrams 47

### Text comprehension



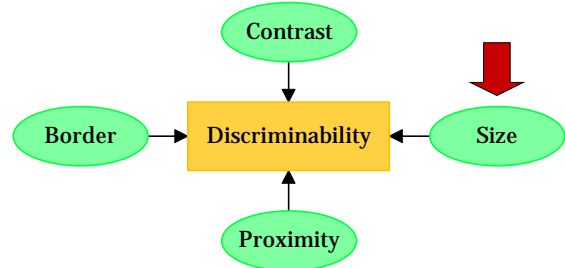
Source: Wheildon, C. *Type and Layout: Are You Communicating or Just Making Pretty Shapes?* Worsley Press, Hastings, Victoria, Australia, 2005

### The 10% Rule



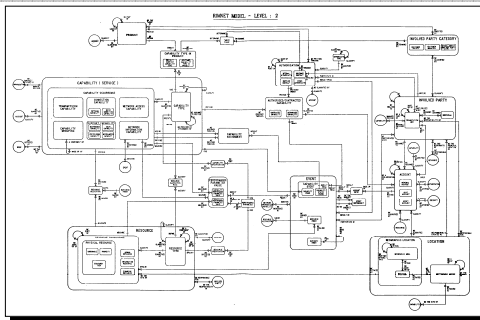
▶ 4/5: Principles for effective diagrams 49

### Determinants of Discriminability



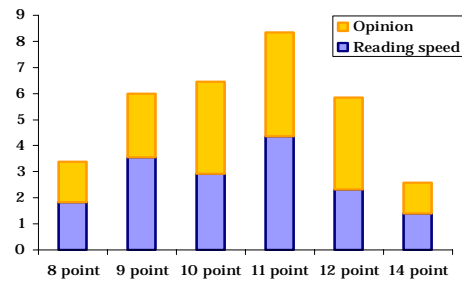
▶ 4/5: Principles for effective diagrams 50

### What's wrong with this diagram?



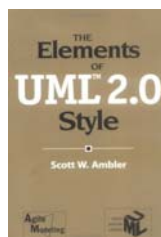
▶ 4/5: Principles for effective diagrams 51

### Legibility of Text



Source: Tinker, M. A. (1963). *Legibility of Print*. Ames, Iowa, USA: Iowa State University Press.

### The Elements of UML Style

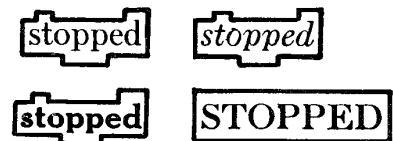


no comment

▶ 4/5: Principles for effective diagrams 53

### Upper vs Lower Case

UPPER CASE REDUCES READING SPEED BY 10-20% AND READERS DON'T LIKE IT (ARE YOU ENJOYING THIS?)



Source: Tinker, M. A. (1963). *Legibility of Print*. Ames, Iowa, USA: Iowa State University Press.

### A real world example

▶ 4/5: Principles for effective diagrams 55

### Principle 1: Discriminability

Diagram elements should be easy to see and differentiate from one another

▶ 4/5: Principles for effective diagrams 56

### Principles for effective diagrams

▶ 4/5: Principles for effective diagrams 57

### Principles for effective diagrams

Those are my principles, and if you don't like them... well, I have others.

- Groucho Marx

▶ 4/5: Principles for effective diagrams 58

### Usage of Visual Variables

Principle	X-position	Y-position	Colour	Value	Size	Shape	Texture	Orientation
1. Discriminability	●	●	●	●	●	●	●	●
2. Modularity	●	●	●	●	●	●	●	●
3. Emphasis	●	●	●	●	●	●	●	●
4. Cognitive integration	●	●	●	●	●	●	●	●
5. Perceptual directness	●	●	●	●	●	●	●	●
6. Structure	●	●	●	●	●	●	●	●
7. Visual expressiveness	●	●	●	●	●	●	●	●
8. Identification	●	●	●	●	●	●	●	●
9. Graphic complexity	●	●	●	●	●	●	●	●

▶ 4/5: Principles for effective diagrams 59

### Cognitive Effectiveness

▶ 4/5: Principles for effective diagrams 60

## The Art and Science of Diagramming

1. What is a (good) diagram?
2. The state of the art
3. How diagrams communicate
4. Principles for effective diagrams
5. Conclusion

	DATA	INFO	PROCESS	METHOD	PROSE	TEXT	METHOD	INFO
FORM (STRUCTURE)								
CONTENT (MEANING)								
USER								
CONTEXT (ENVIRONMENT)								
DESIGNER								
TOOL (SOFTWARE)								
RESEARCH (EVIDENCE)								
TECHNIQUE (PRACTICE)								
TECHNOLOGY (SOFTWARE)								
TECHNIQUE (PRACTICE)								
TECHNOLOGY (SOFTWARE)								

▶ 5/5: Conclusion 62

## The Role of Aesthetics



▶ 5/5: Conclusion

63

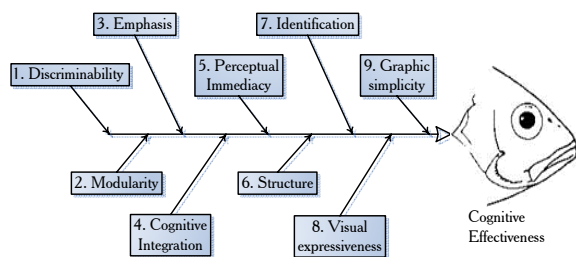
## Current diagramming practices



▶ 5/5: Conclusion

64

## Evidence-Based Diagramming Practice

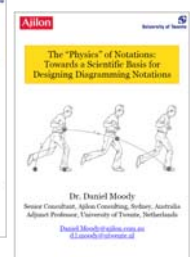


▶ 5/5: Conclusion

65

## Further information

In-house and public courses available for both notation users and notation designers (1 - 2 days)



Contact: [daniel.moody@ajilon.com.au](mailto:daniel.moody@ajilon.com.au)